

Overload Thermal Relays

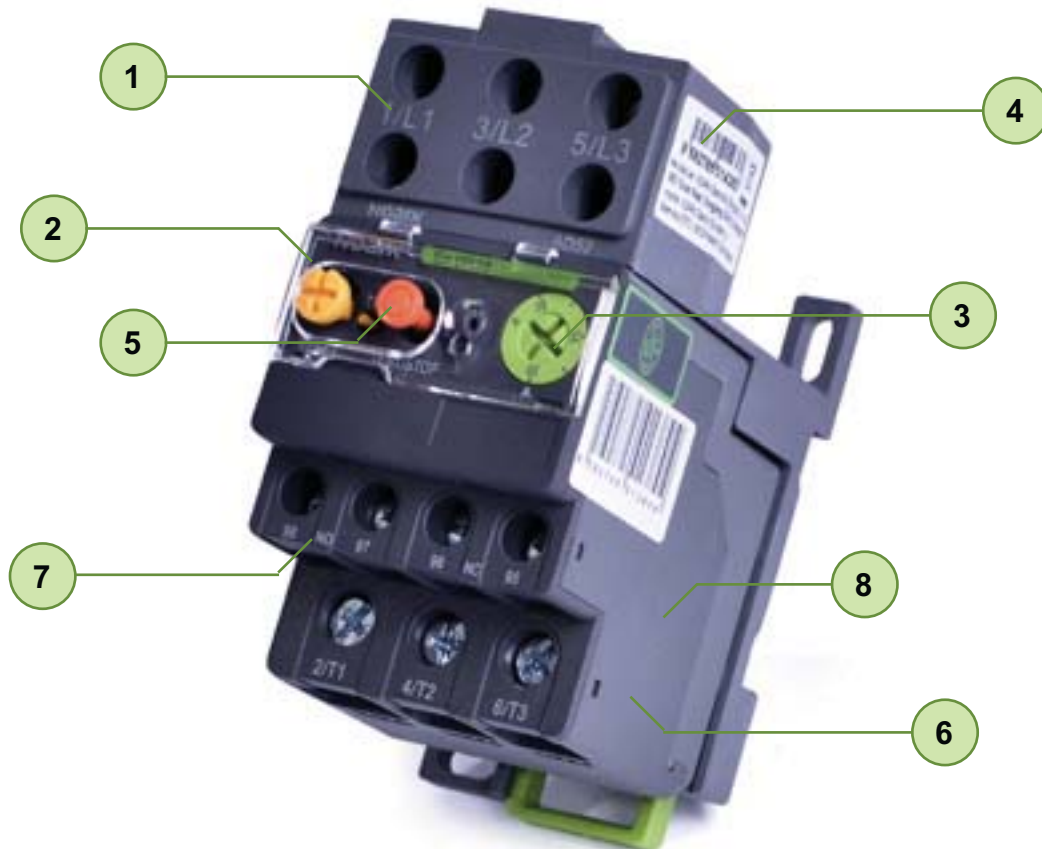

Overload thermal relays

Professional Tips



- 1 5 year warranty
- 2 Five frame sizes
- 3 Rate current up to 500 A
- 4 Direct mounting onto Ex9C(S) or stand alone
- 5 Automatic and manual reset function
- 6 Tripping class 10A
- 7 Integrated 1NO and 1NC contact
- 8 Motor protection against overload or phase lost

Overload thermal relays Ex9R



- Overload thermal relays according to IEC / EN 60947-4-1
- Three frame sizes with rated current up to 100 A at 690 V AC-3
- 3-pole versions
- Tripping class 10A
- For direct mounting onto Ex9C(S) contactors series or as a stand-alone device
- Suitable mainly for motor protection against overload or phase lost
- Mounting onto connected contactor or onto device rail (DIN) 35 mm by means of AD5. adaptor

Ex9R overload thermal relays contactors are designed for protection of motors mainly. These relays can be either combined directly with contactors of Ex9CS and Ex9C series or used as a stand-alone device with AD5 adaptor. Relays are available in three frame sizes for rated non-reduced currents from 0.16 — 100 A.

Size Ex9R12 is designed to match miniature contactors Ex9CS. Version Ex9R38 can be mounted onto contactors Ex9C18 and with spacer (in the scope of delivery of the relay) also with size Ex9C38. The last size Ex9R100 can be combined with Ex9C65 and Ex9C100 directly.

Ex9R relays are equipped with 1 NO and 1 NC auxiliary contacts.

Type Key

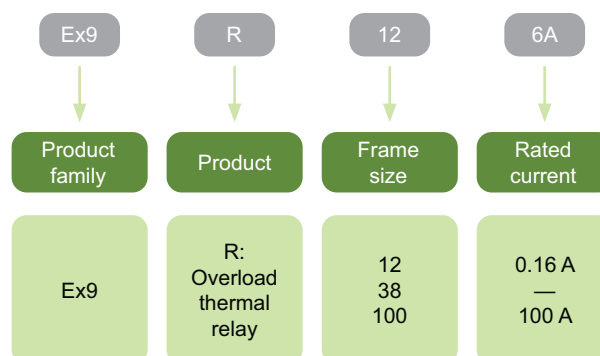

Certification marks



Overload thermal relays Ex9R

Design



Ex9R12
Frame size 12



Ex9R38
Frame size 38



Ex9R100
Frame size 100

Mounting



Direct mounting
onto contactor



Adaptor AD5.



Stand-alone device
with adaptor AD5.

Overload thermal relays Ex9R

Frame size 12

- Overload thermal relays
- For direct mounting onto Miniature Contactors Ex9CS
- Stand-alone device for mounting onto device (DIN) rail 35 mm by means of combination with adaptor AD51
- Automatic and manual reset function
- Tripping class 10A



Current setting range I_n	For contactor frame size	Poles	Auxiliary contacts	Article No.	Type	Packing
0.1 - 0.16 A	Mini (S06, S09, S12)	3	1 NO + 1 NC	101359	Ex9R12 0.16A	1/80
0.16 - 0.25 A	Mini (S06, S09, S12)	3	1 NO + 1 NC	101360	Ex9R12 0.25A	1/80
0.25 - 0.4 A	Mini (S06, S09, S12)	3	1 NO + 1 NC	101361	Ex9R12 0.4A	1/80
0.4 - 0.63 A	Mini (S06, S09, S12)	3	1 NO + 1 NC	101362	Ex9R12 0.63A	1/80
0.63 - 1 A	Mini (S06, S09, S12)	3	1 NO + 1 NC	101363	Ex9R12 1A	1/80
1 - 1.6 A	Mini (S06, S09, S12)	3	1 NO + 1 NC	101364	Ex9R12 1.6A	1/80
1.6 - 2.5 A	Mini (S06, S09, S12)	3	1 NO + 1 NC	101365	Ex9R12 2.5A	1/80
2.5 - 4 A	Mini (S06, S09, S12)	3	1 NO + 1 NC	101366	Ex9R12 4A	1/80
4 - 6 A	Mini (S06, S09, S12)	3	1 NO + 1 NC	101367	Ex9R12 6A	1/80
5.5 - 8 A	Mini (S06, S09, S12)	3	1 NO + 1 NC	101368	Ex9R12 8A	1/80
7 - 10 A	Mini (S06, S09, S12)	3	1 NO + 1 NC	101369	Ex9R12 10A	1/80
9 - 12 A	Mini (S06, S09, S12)	3	1 NO + 1 NC	101370	Ex9R12 12A	1/80

Wiring diagram

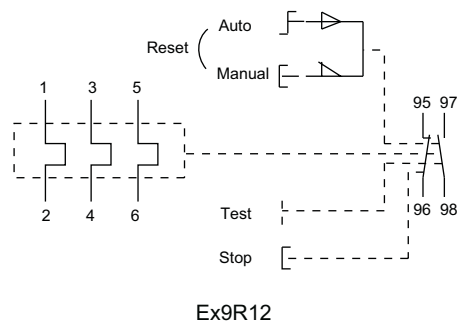

Ex9R12

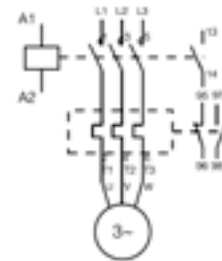

Ex9R12

Overload thermal relays Ex9R

Frame size 38

- Overload thermal relays
- For direct mounting onto Contactors Ex9C09 to Ex9C38 (with included spacer)
- Stand-alone device for mounting onto device (DIN) rail 35 mm by means of combination with adaptor AD56
- Automatic and manual reset function
- Tripping class 10A



Current setting range I_n	For contactor frame size	Poles	Auxiliary contacts	Article No.	Type	Packing
0.63 - 1A	18 (09, 12, 18), 38 (25, 32, 38)	3	1 NO + 1 NC	110327	Ex9R38B 1A	1/60
1 - 1.6A	18 (09, 12, 18), 38 (25, 32, 38)	3	1 NO + 1 NC	110328	Ex9R38B 1.6A	1/60
1.6 - 2.5A	18 (09, 12, 18), 38 (25, 32, 38)	3	1 NO + 1 NC	110329	Ex9R38B 2.5A	1/60
2.5 - 4 A	18 (09, 12, 18), 38 (25, 32, 38)	3	1 NO + 1 NC	110330	Ex9R38B 4A	1/60
4 - 6 A	18 (09, 12, 18), 38 (25, 32, 38)	3	1 NO + 1 NC	110331	Ex9R38B 6A	1/60
5.5 - 8 A	18 (09, 12, 18), 38 (25, 32, 38)	3	1 NO + 1 NC	110332	Ex9R38B 8A	1/60
7 - 10 A	18 (09, 12, 18), 38 (25, 32, 38)	3	1 NO + 1 NC	110333	Ex9R38B 10A	1/60
9 - 13 A	18 (09, 12, 18), 38 (25, 32, 38)	3	1 NO + 1 NC	110334	Ex9R38B 13A	1/60
12 - 18 A	18 (09, 12, 18), 38 (25, 32, 38)	3	1 NO + 1 NC	110335	Ex9R38B 18A	1/60
16 - 24 A	18 (09, 12, 18), 38 (25, 32, 38)	3	1 NO + 1 NC	110336	Ex9R38B 24A	1/60
23 - 32 A	18 (09, 12, 18), 38 (25, 32, 38)	3	1 NO + 1 NC	110337	Ex9R38B 32A	1/60
30 - 38 A	18 (09, 12, 18), 38 (25, 32, 38)	3	1 NO + 1 NC	110338	Ex9R38B 38A	1/60

Wiring diagram

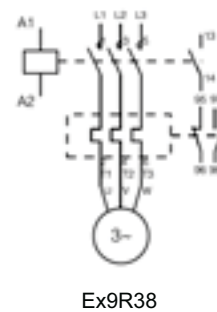
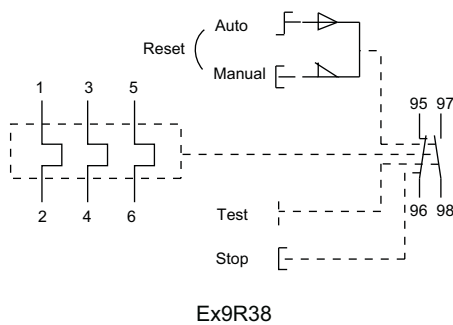

Overload thermal relays Ex9R

Frame size 100

- Overload thermal relays
- For direct mounting onto Contactors Ex9C65 and Ex9C100 (with included spacer)
- Stand-alone device for mounting onto device (DIN) rail 35 mm by means of combination with adaptor AD53
- Automatic and manual reset function
- Tripping class 10A



Current setting range I_n	For contactor frame size	Poles	Auxiliary contacts	Article No.	Type	Packing
23 - 32 A	65 (40, 50, 65), 100 (80, 100)	3	1 NO + 1 NC	101380	Ex9R100 32A	1/24
30 - 40 A	65 (40, 50, 65), 100 (80, 100)	3	1 NO + 1 NC	101381	Ex9R100 40A	1/24
37 - 50 A	65 (40, 50, 65), 100 (80, 100)	3	1 NO + 1 NC	101382	Ex9R100 50A	1/24
48 - 65 A	65 (40, 50, 65), 100 (80, 100)	3	1 NO + 1 NC	101383	Ex9R100 65A	1/24
55 - 70 A	65 (40, 50, 65), 100 (80, 100)	3	1 NO + 1 NC	101384	Ex9R100 70A	1/24
63 - 80 A	65 (40, 50, 65), 100 (80, 100)	3	1 NO + 1 NC	101385	Ex9R100 80A	1/24
80 - 100 A	65 (40, 50, 65), 100 (80, 100)	3	1 NO + 1 NC	101386	Ex9R100 100A	1/24

Wiring diagram

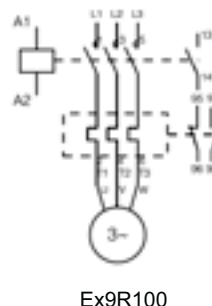
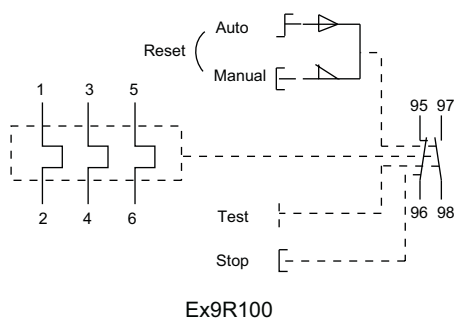

Overload thermal relays Ex9R up to 500 A



- Overload thermal relays according to IEC / EN 60947-4-1
- Two frame sizes with rated current up to 500 A at 690 V AC-3
- 3-pole versions
- Tripping class 10A
- For direct mounting onto Ex9C contactors or as a stand-alone device with AD adaptor
- Suitable mainly for motor protection against overload or phase lost

Ex9R overload thermal relays contactors are designed for protection of motors mainly. These relays can be either combined directly with contactors of Ex9C115-500 series or used as a stand-alone device with AD5 adaptor. Relays are available in two frame sizes for rated non-reduced currents from 80 — 500 A.

Size Ex9R185 is designed to match contactors of frame size 185 (Ex9C115-185). Version Ex9R500 can be mounted onto contactors of 300 (Ex9C225-300) frame size and also with size 500 (Ex9C400-500).

Ex9R relays are equipped with 1 NO and 1 NC auxiliary contacts as the standard.

Type Key

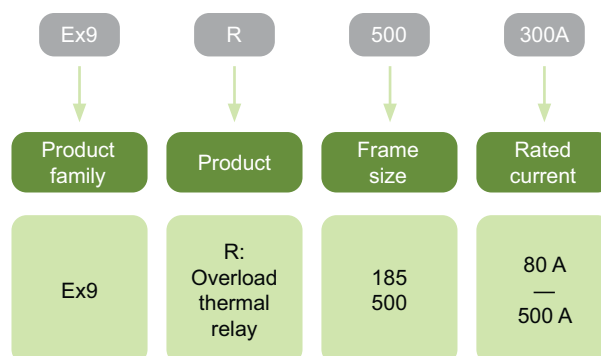

Certification marks



Overload thermal relays Ex9R up to 500 A

Design



Ex9R185
Frame size 185



Ex9R500
Frame size 500

Mounting



Direct mounting
onto Ex9C contactor



Stand-alone device
with adaptor AD5.

Overload thermal relays Ex9R up to 500 A

Frame size 185

- Overload thermal relays
- For direct mounting onto Ex9C115-185 contactors
- Stand-alone device for mounting onto panel by means of combination with adaptor AD54
- Automatic and manual reset function
- Tripping class 10A



Current setting range I_r	For contactors of frame size	Poles	Auxiliary contacts	Article No.	Type	Packing
80 - 115 A	185 (115, 165, 185)	3P	1 NO + 1 NC	106326	Ex9R185 115A	1/8
110 - 150 A	185 (115, 165, 185)	3P	1 NO + 1 NC	106327	Ex9R185 150A	1/8
140 - 185 A	185 (115, 165, 185)	3P	1 NO + 1 NC	106328	Ex9R185 185A	1/8

Frame size 500

- Overload thermal relays
- For direct mounting onto Ex9C225-500 contactors
- Stand-alone device for mounting onto panel by means of combination with adaptor AD55
- Automatic and manual reset function
- Tripping class 10A



Current setting range I_r	For contactors of frame size	Poles	Auxiliary contacts	Article No.	Type	Packing
160 - 225 A	300 (225, 265, 300) 500 (400, 500)	3P	1 NO + 1 NC	106329	Ex9R500 225A	1/8
210 - 300 A	300 (225, 265, 300) 500 (400, 500)	3P	1 NO + 1 NC	106330	Ex9R500 300A	1/8
280 - 400 A	300 (225, 265, 300) 500 (400, 500)	3P	1 NO + 1 NC	106331	Ex9R500 400A	1/8
380 - 500 A	300 (225, 265, 300) 500 (400, 500)	3P	1 NO + 1 NC	106332	Ex9R500 500A	1/8

Wiring diagram

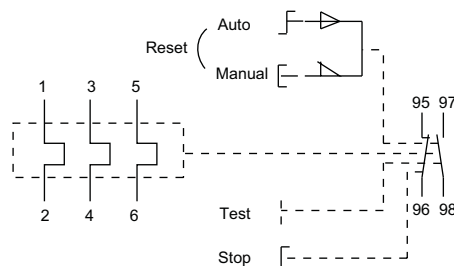

Technical Data Ex9R

Overload thermal relays Ex9R12, Ex9R38, Ex9R100

General parameters

Thermal overload relays

Ex9R12 for direct mounting onto Contactors Ex9CS

Ex9R38B for direct mounting onto Contactors frame size 18, 38 (with spacer)

Ex9R100 for direct mounting onto Contactors frame size 65, 100

For stand-alone applications by means of adaptor AD5.

Suitable mainly for motor protection against overload or phase lost

With built-in auxiliary contacts 1 NO + 1 NC

Accessories

Adaptors for stand-alone use	AD51, AD56, AD53	101436, 110339, 101438
------------------------------	------------------	------------------------

Electrical parameters

	Ex9R12	Ex9R38	Ex9R100
Tested according to	IEC/EN 60947-4-1		
Rated op. voltage U_e	690 V AC		
Rated insulating voltage U_i	690 V AC		
Rated impulse withstand voltage U_{imp}	6 kV	6 kV	6 kV
Rated frequency	50/60 Hz		
Tripping Class	10A	10A	10A
Current setting range (per frame size)	0.1 — 12 A	1 — 38 A	23 — 100 A
Tripping threshold	$1.14 \pm 0.06 \times I_n$		
Phase failure detection	30 % in a phase		
Maximum short circuit protection fuse	25 A gG/gL	80 A gG/gL	160 A gG/gL
Reset	Manual or Auto		
Min. op. voltage per AX contact U_{min}	17 V AC, 3 V DC		
Rated thermal current I_{th} of AX cont.	5 A 600 V AC, 1 A 300 V DC		
Rated op. current I_e , AC-15 of AX	1.64 A / 230 V, 0.95 A / 400 V		
Rated op. current I_e , DC-13 of AX	0.13 A / 220 V		
Min. operational current I_{min} of AX	5 mA AC, 5 mA DC		
Max. back-up fuse of AX	6 A gG/gL, 6 A MCB char. B		
Conditional short circuit current I_k with max. back-up fuse of AX	1 kA		

Mechanical parameters

	Ex9R12	Ex9R38	Ex9R100
Tripping indicator	yellow	yellow	yellow
Device width	45 mm	45 mm	72 mm
Device height	72 mm	65.5 mm	80 mm
Device depth	68 mm	94 mm	117 mm
Mounting onto	Ex9CS, AD51	Ex9C09 — 38, AD56	Ex9C40 — 100, AD53
Degree of protection	IP20		
Terminals	lift		
Terminal capacity	1 — 4 mm ²	1 — 10 mm ²	4 — 35 mm ²
Fastening torque of terminals	1.7 Nm	2.5 Nm	9 Nm
Weight	0.16 kg	0.14 kg	0.51 kg
Vibration resistance IEC 68-2-6	2 g, 5 — 300 Hz		
Shock resistance IEC 68-2-27	15 g, 11 ms		

Technical Data Ex9R

Overload thermal relays Ex9R12, Ex9R38, Ex9R100

Dimensions

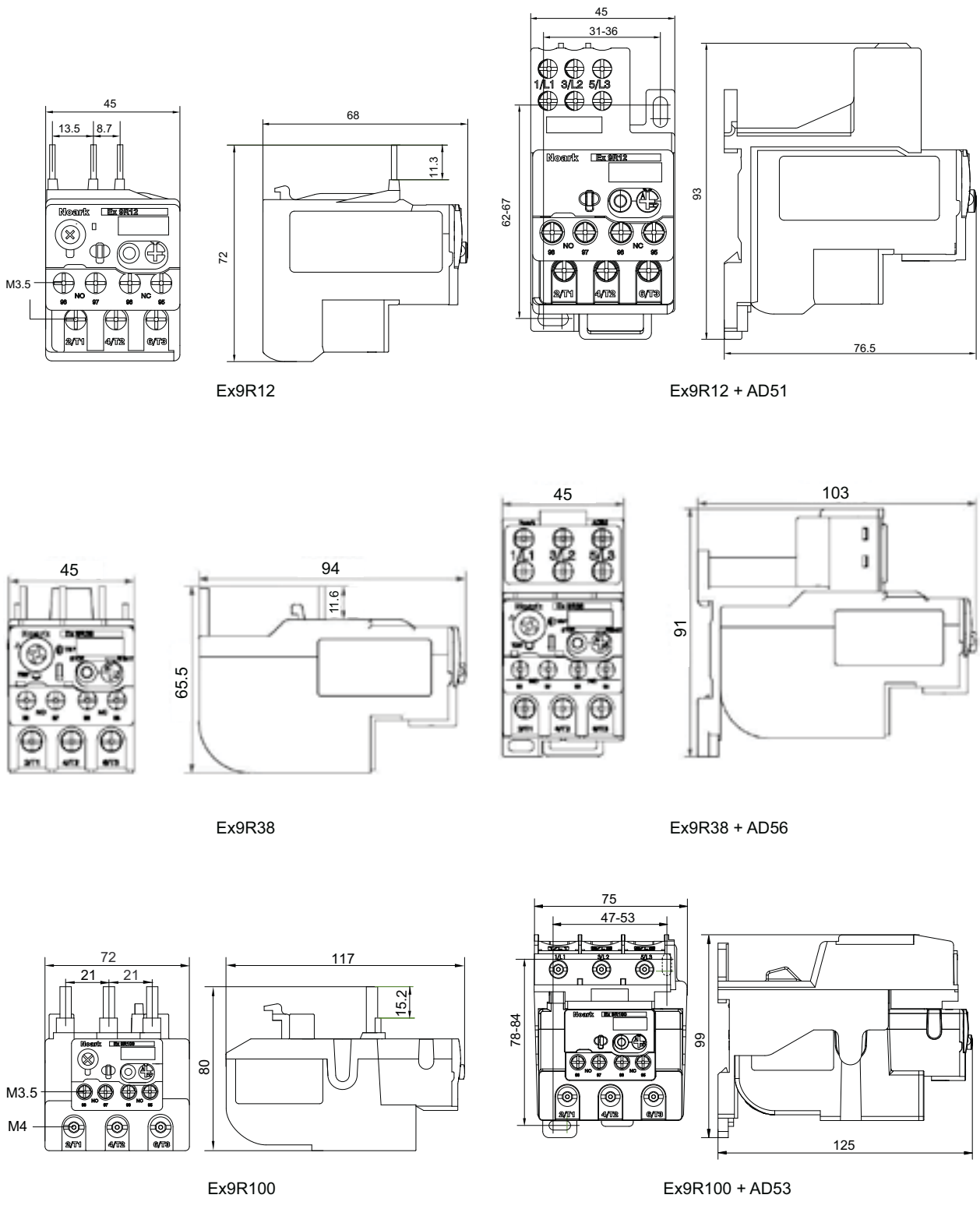

Technical Data Ex9R

Overload thermal relays Ex9R12, Ex9R38, Ex9R100

Wiring diagrams

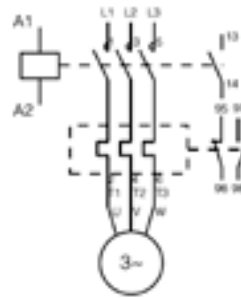
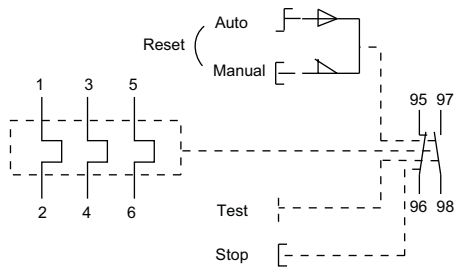

Tripping characteristics

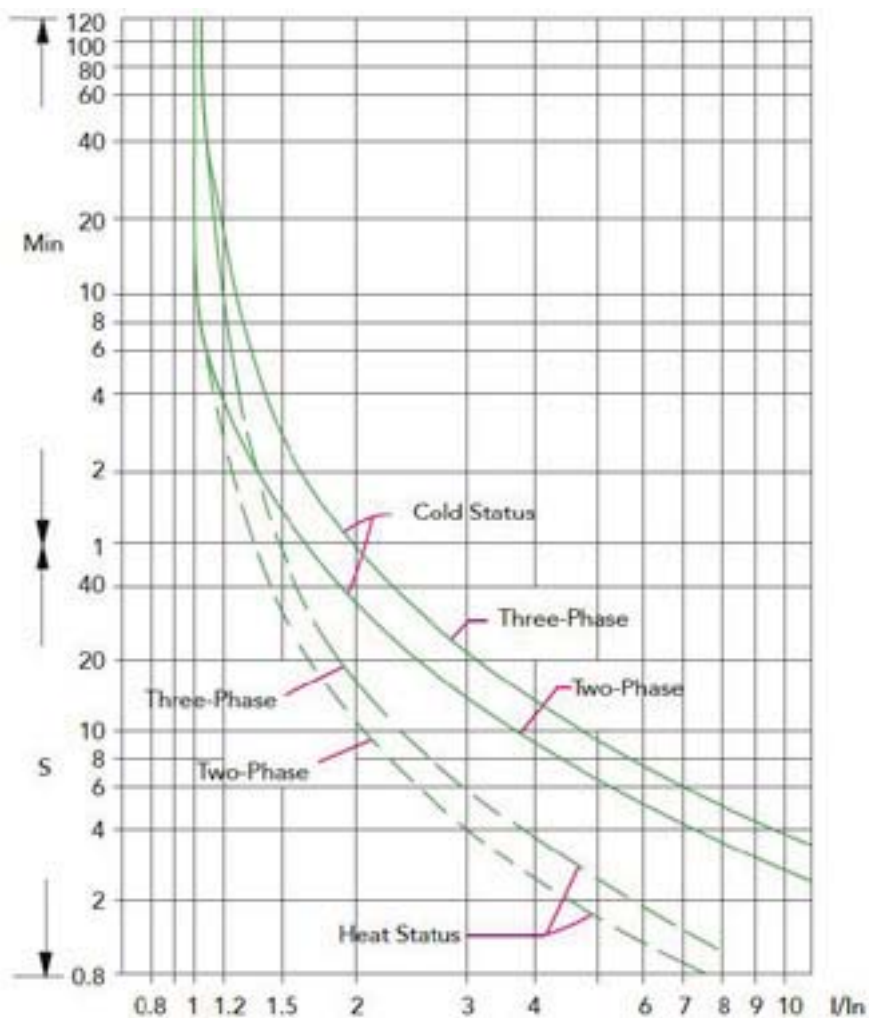

Technical Data Ex9R500

Overload thermal relays Ex9R185, Ex9R500

General parameters

Overload thermal relays

Ex9R185 for direct mounting onto contactors of frame size Ex9C185

Ex9R500 for direct mounting onto contactors of frame size Ex9C300, Ex9C500

For stand-alone applications by means of adaptor AD5

Suitable mainly for motor protection against overload or phase lost

With built-in auxiliary contacts 1NO + 1NC

Accessories

Adaptors for stand-alone use

AD54, AD55

107968, 107969

Electrical parameters

	Ex9R185	Ex9R500
Tested according to	IEC/EN 60947-4-1	
Rated operating voltage U_e	690 V AC	
Rated insulating voltage U_i	690 V AC	
Rated impulse withstand voltage U_{imp}	6 kV	6 kV
Rated frequency	50/60 Hz	
Tripping Class	10A	10A
Current setting range I_r (per frame size)	80 — 185 A	160 — 500 A
Tripping threshold	$1.14 \pm 0.06 \times I_r$	
Phase failure detection	30 % in a phase	
Maximum short circuit protection fuse	315 A gG/gL	800 A gG/gL
Reset	Manual or Auto	
Minimum operating voltage U_{min} of AX	17 V AC / 3 V DC	
Rated thermal current I_{th} of AX	5 A	
Rated op. current I_e , AC-15 of AX	1.64 A / 230 V, 0.95 A / 400 V	
Rated op. current I_e , DC-13 of AX	0.13 A / 220 V	
Min. operational current I_{min} of AX	5 mA AC, 5 mA DC	
Max. back-up fuse of AX	6 A gG/gL, 6 A MCB char. B	
Conditional short circuit current I_k with max. back-up fuse of AX	1 kA	

Mechanical parameters

	Ex9R185	Ex9R500
Tripping indicator	blank-yellow	blank-yellow
Device width	120 mm	145 mm
Device height	133 mm	149 mm
Device depth	136 mm	146 mm
Mounting onto	Ex9C115 — 185, AD54	Ex9C225 — 500, AD55
Degree of protection	IP20	
Terminals	connection plates for M8 screw	connection plates for M10 screw
Terminal capacity	25 — 95 mm ²	50 — 240 mm ²
Fastening torque of terminals	18 Nm	35 Nm
Altitude	≤ 2000 m	
Relative humidity	≤ 90 %	
Ambient temperature	-20 — +55 °C	
Weight	1.5 kg	1.9 kg
Vibration resistance IEC 68-2-6	2 g, 5 — 300 Hz	
Shock resistance IEC 68-2-27	15 g, 11 ms	

Technical Data Ex9R500

Overload thermal relays Ex9R185, Ex9R500

Dimensions

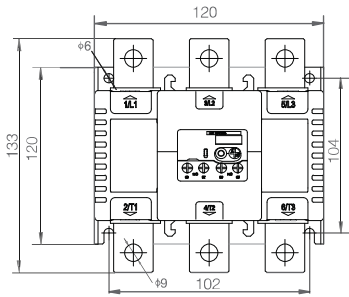

Ex9R185

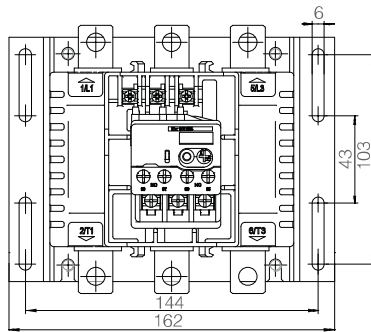
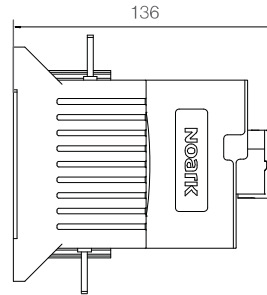

Ex9R185 + AD54

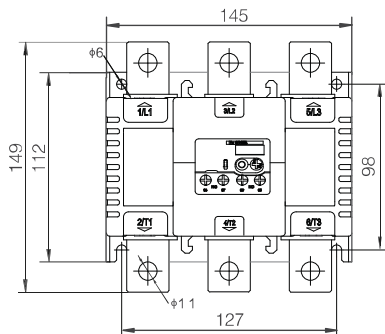
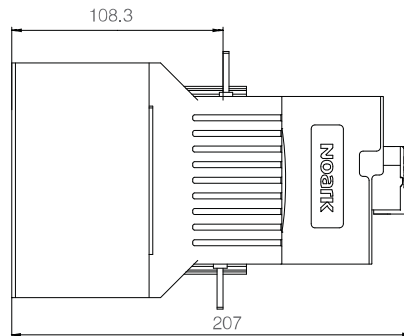

Ex9R500

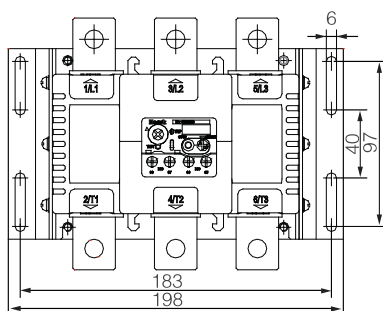
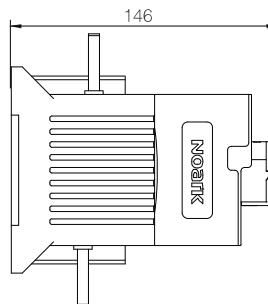

Ex9R500 + AD55

